

Corrections Facility Mirrors

Polycarbonate Half Dome Mirror

Assembly Guide:

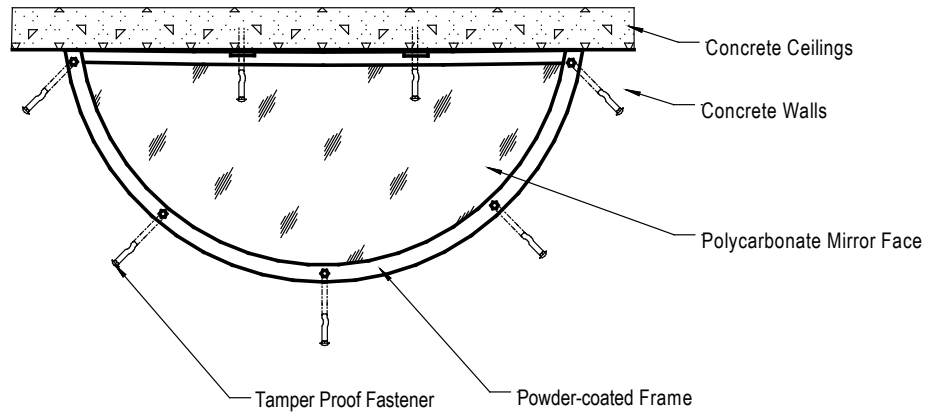

NOTE: If installing with Rawl Spikes, it is recommended to use a punch. This is to eliminate damage to the mirror and powder-coated frames.

FOAM INSERTS: When installing the optional foam inserts DO NOT remove the grey protective film on the inserts, as this may cause damage to the mirror face.

Cleaning Instructions

Because polycarbonate is softer than glass clean with soap and water and then with a soft, lint free, damp cloth.

DO NOT USE:

- abrasives
- acids
- solvents such as petrol and laquer thinners

POLISH:

Use a non-abrasive polish, such as Johnson's Pledge for a clear bright reflection.

Saturate a clean soft cloth with polish, then spray the mirror face with polish. Wipe the wetted cloth over the mirror surface. With a another clean dry cloth buff the mirror face until it is clear of polish.

GRAFFITI REMOVAL:

Any graffiti should be removed from the mirror face as soon as possible and preferably within 24 hours. To remove graffiti, use a non-abrasive substance such as De-Solv-it stain remover.

Not all graffiti cleaning agents are suitable. Failure to use an approved cleaning agent may damage the mirror surface.

POWDER COATED FRAMES:

Do not use harsh cleaning products or products that will leave a residue, as this will damage the powder coating which protects the frame.

AC-PHD-52



See Over For Suggested
Fastening Methods



Distributed in Australia By:
Acril Convex Mirrors
41 Quinn Drive, Keilor Park, VIC 3040
Free Phone: 1800-802-506:
Email: sales@acrilconvex.com.au

Made in New Zealand By:
Bennett Mirror Technologies Ltd
Email: mirrors@bennettmirror.com
www.duravision.net

Corrections Facility Mirrors

Suggested Fastening Methods

RAWL SPIKES

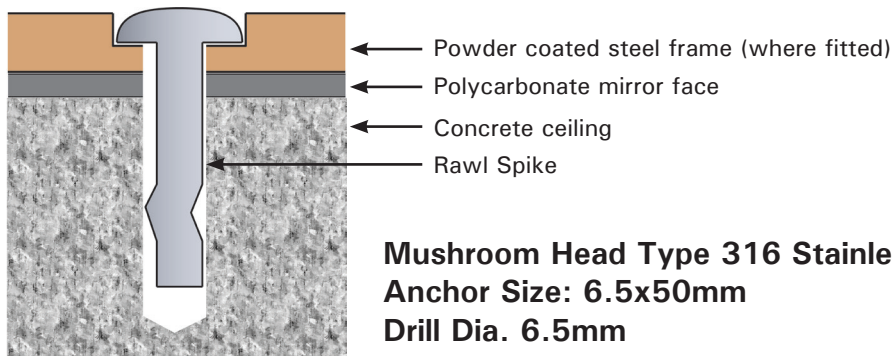

Mushroom Head Type 316 Stainless Steel SPIKE.
Anchor Size: 6.5x50mm
Drill Dia. 6.5mm

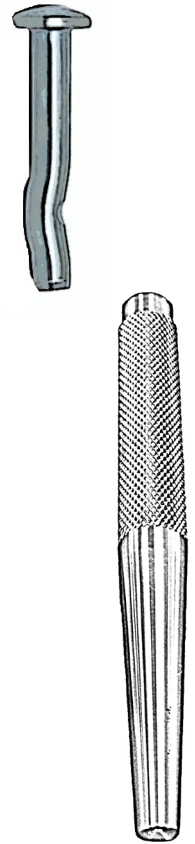

Installation: Drill a hole into the base material to a depth of at least 60mm. The tolerances of the drill bit used should meet the requirements of ISO/ DIN Standard 8035. Blow the hole clean of dust and other material. Drive the Spike through the appropriate mirror face hole (and frame when used) ensuring the head is sitting firmly against the mirror or frame and recessed as shown in the above diagram.

NOTE: Care should be taken not to overdrive the Spike so as to cause damage to the powder coated surface of the frame. Finish off by applying (optional) a bead of non-pick sealant around the mirror or frame and the wall to prevent the secretion of small objects (eg razor blades etc).

DuraVision Rawl Spike Punch:

The DuraVision designed punch for inserting spikes can significantly reduce the risk of damaging the mirror face and frame during installation.

TORX SECURITY SCREWS

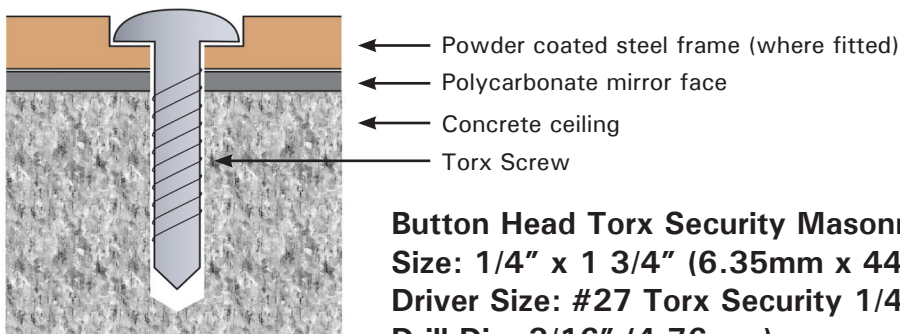

Button Head Torx Security Masonry Screw
Size: 1/4" x 1 3/4" (6.35mm x 44.45mm)
Driver Size: #27 Torx Security 1/4" (6.35mm) Hex Bit
Drill Dia: 3/16" (4.76mm)



Installation: It is recommended to use a 3/16" (4.76mm) Straight Shank Tanged Bit to drill the hole. The hole must be at least 2" or 50mm overall depth and free of any debris. By using the #27, 1/4" (6.35mm) Hex Bit the special Hi-Lo thread literally taps into masonry materials. The high, sharp thread with its notched cutting edge cuts deeply and easily. The alternating low thread provides stability for fast, accurate driving. Torx Tamperproof masonry screws are the optimal fastening solution for use in concrete, brick, or hollow block.

NOTE: It is the end-user's responsibility to ensure the suitability of this product for their particular application.