

Size (Nominal)	600mm (300x300mm)	900mm (450x450mm)
DESCRIPTION	PART NUMBER	PART NUMBER
Mirror Face and Frame	17527HD	17560HD
Foam Insert Only	21197	21198
SPECIFICATIONS		
Polycarbonate Thickness	3mm	3mm
Mirror Face Depth of Curve	210mm	320mm
Distance from the Ceiling (A)	240mm	345mm
Distance from Corner to Frame Edge (B)	340mm	485mm
Mounting Holes	7 x 7mm	8 x 7mm
Tamper Proof Fasteners	Not Included	Not Included
Encapsulating Steel Frame	Triple Powder Coated	Triple Powder Coated

Australian Design No. 142608

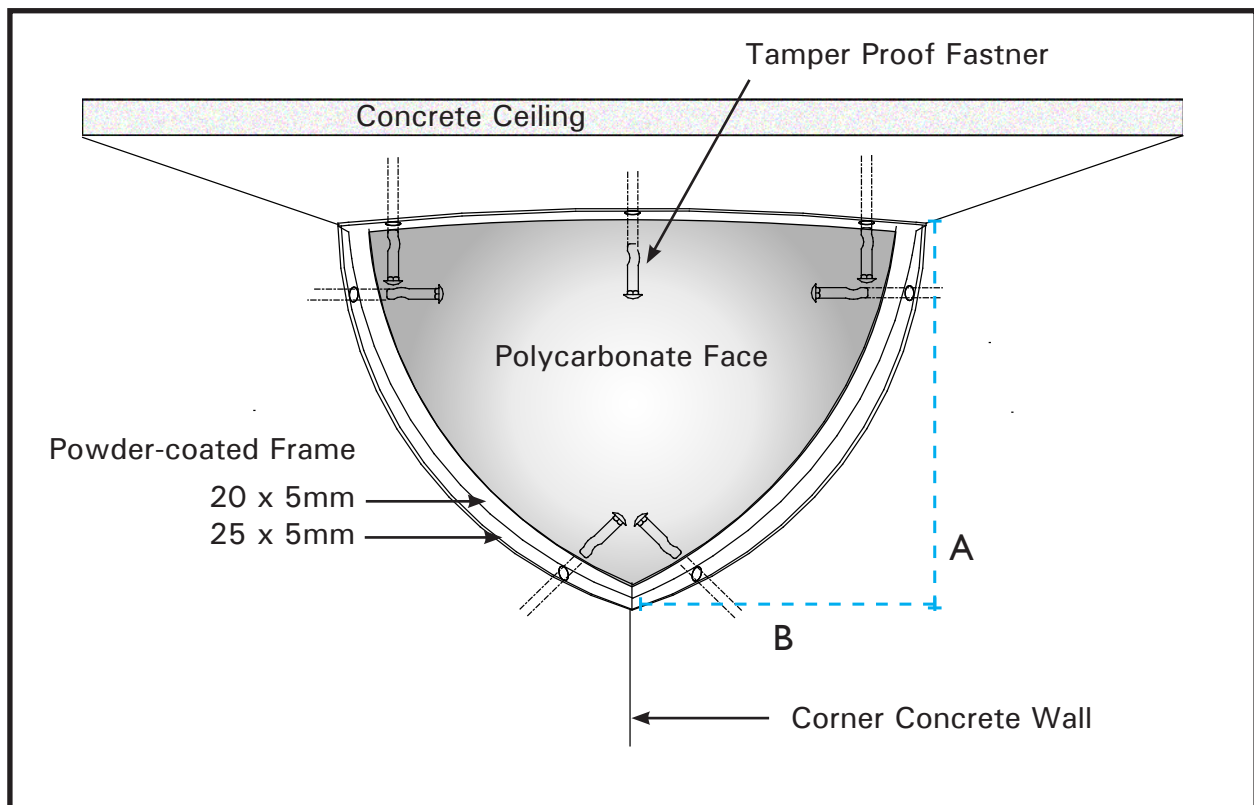

	ASTM Method	Unit	Value
Tensile Strength	D 368	PSI	4,500
Impact Strength	D 256	Ft-lb/inch	17.0

Quarter Dome Mirror with Captive Frame - Aust. Design No. 142608

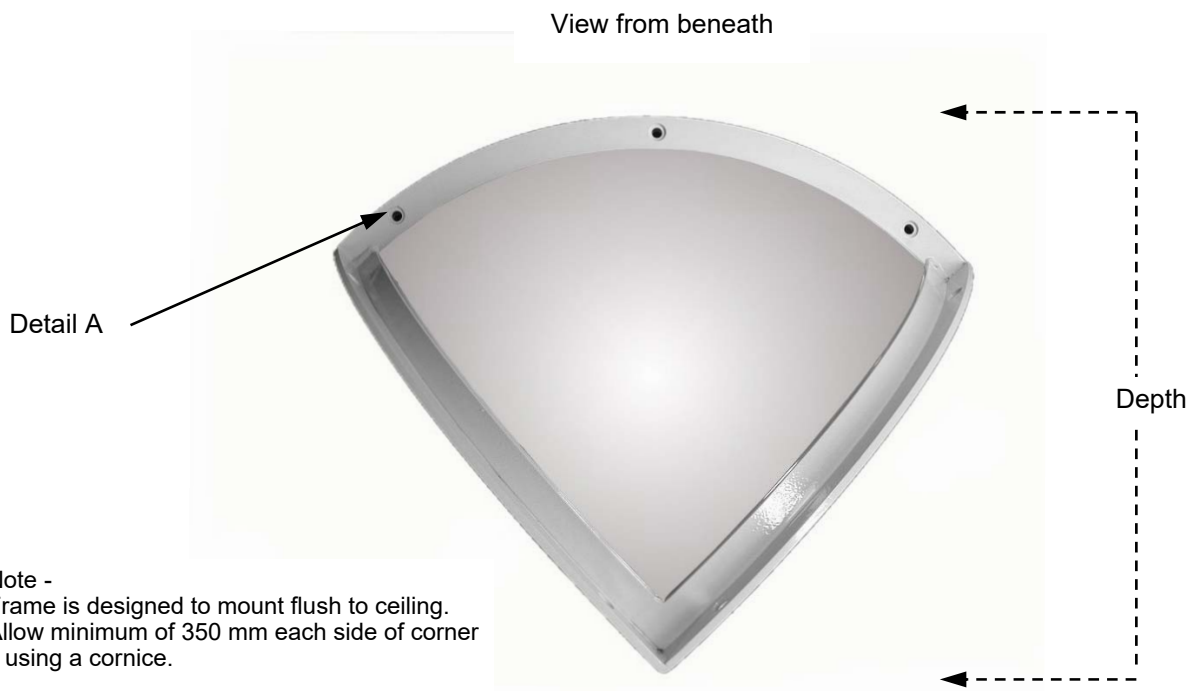

Note -
Frame is designed to mount flush to ceiling.
Allow minimum of 350 mm each side of corner
if using a cornice.

Polycarbonate quarter dome mirror with frame.
The Australian design number is your guarantee of authenticity.
Quote the following number when specifying this product.

Australian Design Number 142608

- Mounting holes 7mm diameter.
- Frame 25 x 5 mild steel section
- Measurements allow for clearance
- Optional hi-density foam insert available for polycarbonate mirror only

Close up of mounting hole detail 'A'

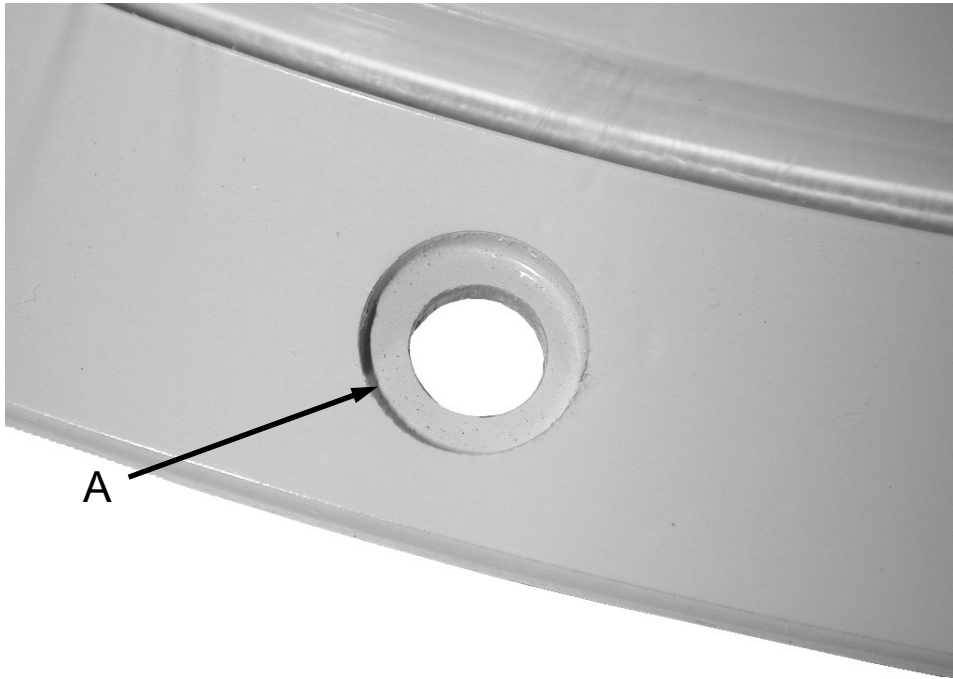

A

Detail A

Mounting holes 7mm diameter.
Frame 25 x 5 mild steel section