

Size (Nominal)	500mm (250x250mm)
DESCRIPTION	PART NUMBER
Mirror Face and Frame	16525HD
SPECIFICATIONS	
Stainless Steel Thickness	1.2mm
Mirror Face Depth of Curve	220mm
Distance from the Ceiling (A)	230mm
Distance from Corner to Frame Edge (B)	260mm
Mounting Holes	7 x 7mm
Tamper Proof Fasteners	Not Included
Encapsulating Steel Frame	Triple Powder Coated

Australian Design No. 142608

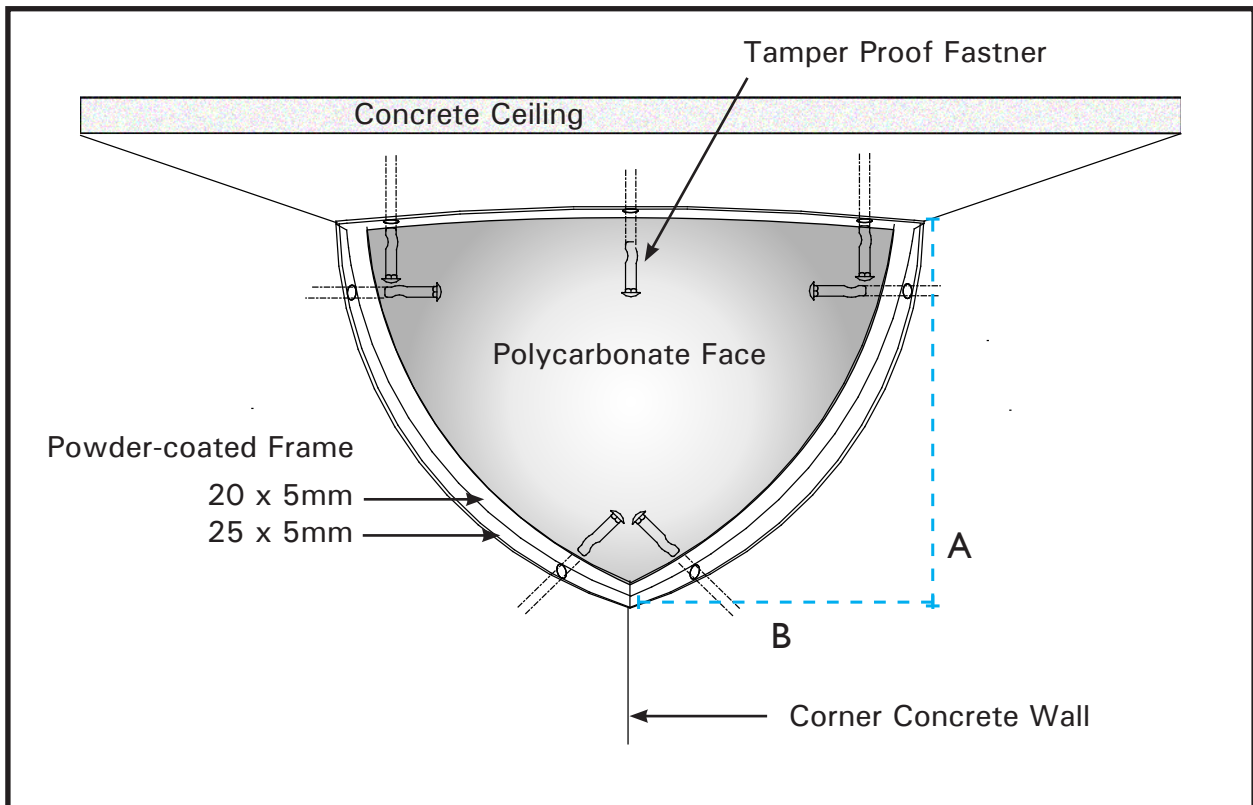

## Quarter Dome Mirror with Captive Frame - Aust. Design No. 142608

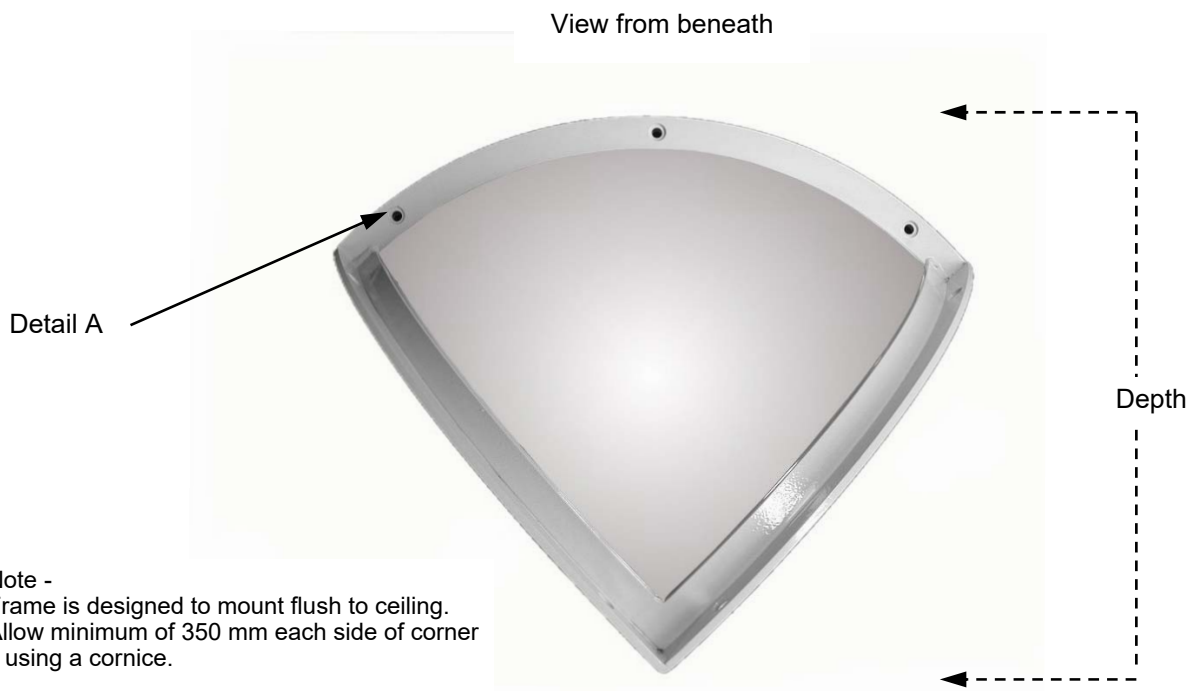

Note -  
Frame is designed to mount flush to ceiling.  
Allow minimum of 350 mm each side of corner  
if using a cornice.

Polycarbonate quarter dome mirror with frame.  
The Australian design number is your guarantee of authenticity.  
Quote the following number when specifying this product.

**Australian Design Number 142608**

- Mounting holes 7mm diameter.
- Frame 25 x 5 mild steel section
- Measurements allow for clearance
- Optional hi-density foam insert available for polycarbonate mirror only

## Close up of mounting hole detail 'A'

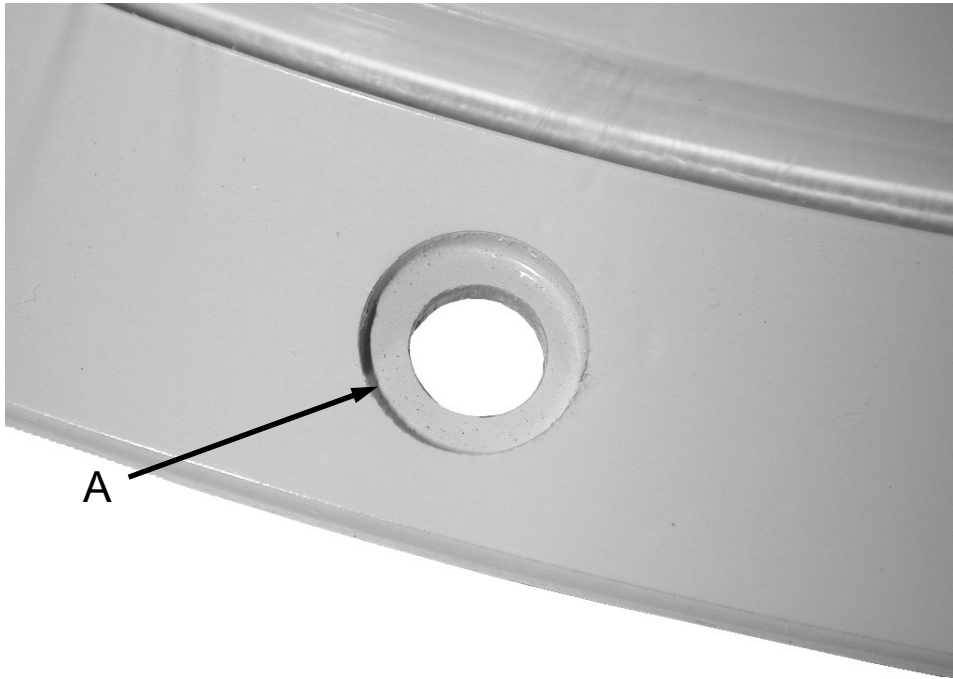

Detail A

Mounting holes 7mm diameter.  
Frame 25 x 5 mild steel section